

## LEAD RUBBER BEARINGS: A SOLUTION FOR THE SEISMIC PROTECTION OF STRATEGIC BUILDINGS

Mauro SARTORI<sup>1</sup>, Giorgio BRESAOLA<sup>2</sup>, Burak TURKDONMEZ<sup>3</sup>, Ivan ALENDE<sup>4</sup> & Ivica ZIVANOVIC<sup>5</sup>

**Abstract:** *Seismic protection of strategic buildings is a real need that governments worldwide have to satisfy in order to guarantee their functionality after earthquake. Any earthquake could unlikely provoke a huge number of injured people which need immediate help, or the whole functionality of public institution offices to assure the continuity of the basic services to the community.*

*This kind of seismic protection can be achieved through the base isolation applied both to new structures and as seismic retrofitting of existing structures, to fit the requirements of the updated standards. In particular, this paper shows how Lead Rubber Bearings can be the suitable solution for the seismic protection of hospitals all around the world when designed and tested according to the different applicable standards.*

*First, the retrofitting of Marmara Hospital in Istanbul is presented together with the challenge in term of performance required and the installation method*

*Secondly, two applications in Chile on new structures are shown: the base isolation of Curicò Hospital and the base isolation of the Investigation Police in Santiago.*

*The paper describes how the needs of the designers have been met through a customized design and testing according to the different applicable standards in two of the most seismic countries in the world.*

### Introduction

Strategic facilities like schools and hospitals have a primary role in the civil protection sphere to guarantee the continuity of the main services to citizenry, especially after a seismic event. Governments worldwide are always more and more sensible to seismic protection, especially when large cities faced post-seismic event trauma. They frequently make the choice of base isolation technology for the construction or retrofitting of strategic facilities to guarantee the continuity of these services critical for the population. Consequently, many hospital and other emergency buildings are base isolated in earthquake prone cities.

The continuous improvement of the knowledge in the field of civil protection, with particular reference to the seismic activity, necessarily brings to an update of the local seismic hazard map. Consequently, both from legislative and safety point of view, the continuous upgrade and compliance to the existing standards of those structures is of primary importance to supply such service to the citizenry.

Of course, also the seismic protection techniques have been improved during the last years, both for the type of material used and for their application. These techniques are more often used in structures even more irregular both in plan and in height, especially if they are built in very high seismic zones, or because very severe performances are request after seismic improvement.

Moreover, an effective design of the isolation system allows the structure to be fully operational even after major earthquakes. Seismic protection of stiff structures by base isolation has been widely reported on the past years and has been the subject of many technical publications.

---

<sup>1</sup>Technical Manager, Tech. Dept, Freyssinet Product Company Italia, Milan, Italy, mauro.sartori@freysinet.com

<sup>2</sup> Project Engineer, Tech. Dept, Freyssinet Product Company Italia, Milan, Italy

<sup>3</sup> Project Manager, Freysas, Istanbul, Turkey

<sup>4</sup> Area Manager, LATAM South, Freyssinet, Santiago de Chile, Chile

<sup>5</sup> Deputy Director, Tech Department, Freyssinet, Rueil-Malmaison, France

The main challenge required when designing an isolation system in different countries and especially when using Lead Rubber Bearings is to get compliance with the many different standards applicable as well as design specifications. Europe is of course requiring CE marking for products supplied within their countries and consequently the application of the reference standard EN 15129. This standard provides its criteria for checking the adequacy of performance and its constancy along the mass production. On the other hand, standards in American continent are almost referring to ASCE design code and even South America countries, have their own standards written having ASCE standard as a reference. Criteria for checking performances when using ASCE are totally different than when using EN 15129 and a big challenge is required to design and manufacture LRB in accordance with the requirements of the two different standards. This is only possible with a deep knowledge of the product, following it from design to manufacture and then testing, keeping under control the different phases.

Freyssinet, with its complete approach offered to the market, is able to design in its technical department the devices which are then manufactured at FPC Rubber (Freyssinet rubber factory) with a strict quality control on raw materials performed in the internal material laboratory and on the vulcanization process, and tested at ISOLAB (Freyssinet dynamic testing facility) able to perform prototype tests and Quality control tests on finished product testing full scale the Lead Rubber Bearings in dynamic conditions.

The experience obtained thanks to hundreds of tests under the most different deformation and stress conditions allows to have the necessary knowledge to propose safely solutions to worldwide contractors who look for an integrated approach able to guarantee the success of the project.

This paper aims to describe few important applications in two of the most seismic area in the world: Turkey and Chile. Few case studies are presented where base isolation with the use of Lead Rubber Bearings have been applied with successful results.

## Hospital de Curicó

### *Description*

A successful application of base isolation to new structures is represented by the isolation of Curicó new Hospital, located in the Maule region in Chile. In 2010 this region suffered a major earthquake (8.8 on the Richter scale).



Figure 1. Hospital de Curicó

Serious structural damages were experienced by many structures, including the main hospital which was demolished soon after.

The new hospital construction begun in mid-2016 and will be completed for the year 2020. It will be one of the most emblematic in the country with 400 beds, 7 stories above ground and 2 at basement level.



*Figure 2. Hospital de Curicó erection*



*Figure 3. Hospital de Curicó render*

#### *Isolation system characteristics*

The isolation system, designed according to Chilean standard NCh2745, is composed by a combination of high damping rubber bearings, lead rubber bearings and low-friction flat sliders for a total amount of 370 devices.

Freyssinet supplied 150 lead rubber bearings that have been successfully tested according to the Chilean standard, one of the most severe standards in the seismic field requiring initial qualification test on prototypes and quality control test on 100% of the supplied quantity.

LRB 0,8-10 $\Phi 750 \times 150$				
Maximum seismic vertical load	P	9250	kN	
Seismic design displacement	$D_D$	$\pm 160$	mm	
Maximum total seismic displacement	$D_{TM}$	$\pm 300$	mm	
Effective stiffness at DD	$K_{eff}$	3,02	kN/mm	

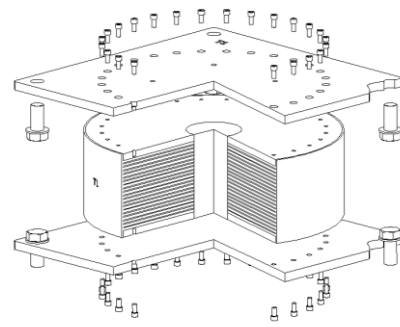

Table 1. Curicó: LRB main characteristics

Figure 4. Curicó: LRB 3D view

*Test requirements and results*

This project was made even more challenging by the additional acceptance criteria set by the client, requiring a maximum variation on the effective stiffness of:

	<b><math>K_{eff}</math></b>
Individual	$\pm 20\%$
Group average	$\pm 10\%$

Table 2. Curicó: Test tolerance at design displacement

Prototype Tests have been performed in an independent testing facility to assess the design parameters while Quality control tests have been carried out in coupled configuration at ISOLAB, Freyssinet internal dynamic laboratory located in Montebello della Battaglia (Pavia, Italy).



Figure 5. Test equipment: 50MN vertical capacity

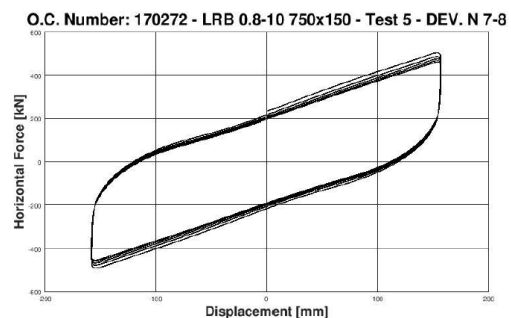

Figure 6. Curicó: Horizontal cyclic test

Quality control test have shown excellent outcomes in terms of accuracy and consistency of the isolator characteristics and manufacturing quality.

The group average effective stiffness variation registered was an outstanding +3%.

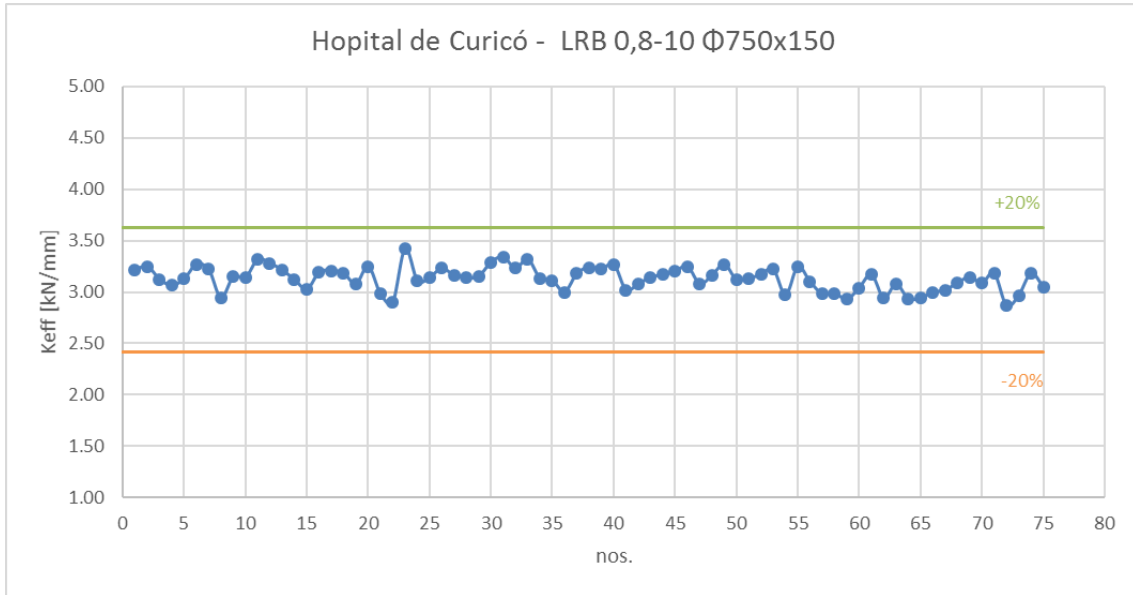

Figure 7 – Curicó: Quality control results

### Edificio PDI

*Description*

Base isolation has been recently implemented to the Chilean Investigation Police (P.D.I.) new headquarter located in Pudahuel, Santiago de Chile. The building replaces the old one that was seriously damaged in the 2010 earthquake.



Figure 8. Edificio PDI

The complex will have a main building of seven stories above the street level and one underground. Offices, laboratories, auditorium, shooting range and other facilities will be erected on a construction site of 15000 square meters.

*Isolation system characteristics*

The isolation system, supplied entirely by Freyssinet, is composed by one type of high damping rubber bearings and two types of lead rubber bearings for a total of 40 devices. It has been designed and tested according to the Chilean standard NCh2745.

The main difficulty related to this project was represented by the particular combination of performances required: very low horizontal stiffness with high vertical loads as well as horizontal displacements applied. The combination of these requirements brings to design the isolators, both lead rubber bearings and high damping rubber bearings, with huge dimension and many thin rubber layers to guarantee a good stability under testing and earthquake excitations with consequent challenge to manufacture them.

As an example, the HDRB characteristics are reported:

<b>HDRB 0,4-10 Ø920x266.5</b>			
Maximum seismic vertical load	P	9585	kN
Seismic design displacement	D <sub>D</sub>	±362	mm
Maximum total seismic displacement	D <sub>TM</sub>	±482	mm
Effective stiffness at DD	K <sub>eff</sub>	1.00	kN/mm

Table 3. PDI: HDRB main characteristics

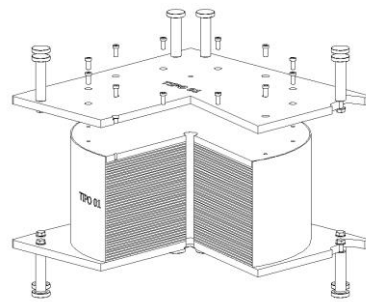

Figure 9. PDI: HDRB 3D view

*Test requirements and results*

As for all the Latin-American projects, small tolerances were required for the quality control test performed on 100% of the supplied quantity.

	<b>K<sub>eff</sub></b>	
	<b>HDRB</b>	<b>LRB</b>
Individual	± 20%	± 15%
Global (system)	± 10%	

Table 4. PDI: Test tolerance at design displacement

Both prototype and quality control tests have been carried out at ISOLAB on its 70MN testing machine. All the requirements prescribed by the reference standard as well as the project-specific acceptance criteria have been fulfilled.



Figure 10. Test equipment: 70MN vertical capacity



Figure 11. PDI: Device under testing.

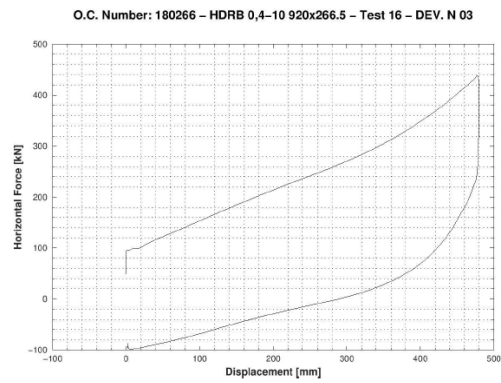

Figure 12. PDI: Stability test at DTM

Quality control tests results have shown once again a very small production variability with all the effective stiffness within the individual tolerance and the group average perfectly centered around the design value.

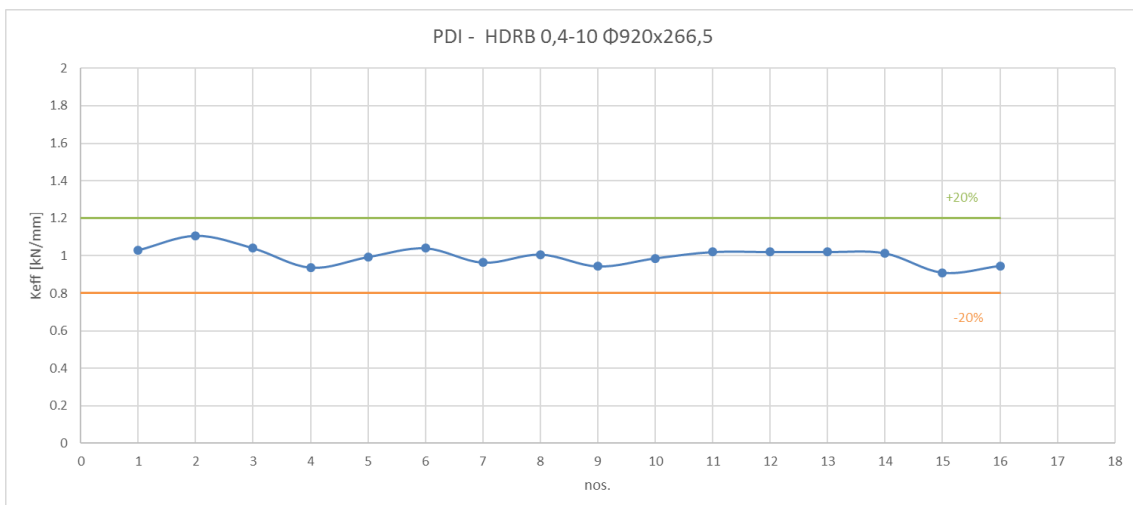

Figure 13. PDI: Quality control results

## Başibüyük Marmara University Hospital

### Description

The Başibüyük Marmara University Hospital, one of Istanbul most important hospitals, is located in the Asiatic side of the city, on the Coast of Marmara Sea.

The building, composed by 16 independent blocks of rectangular shape raising to different heights and a block designated to car park, never started his duty, despite it has been built in 1991.



Figure 14. Marmara: view of the different blocks of the building

After the introduction of the seismic standard in 1998, the structure has been retrofitted in 2002 through the introduction of concrete shear walls and column jacketing.

Nevertheless, after the incoming of the 2007 new seismic standard, the retrofitting recently performed did not satisfy the request of the new standard and a new intervention was needed.

### Isolation system characteristics

The optimal solution which was able to satisfy both the standard requirements, granting at the same time a satisfactory architectural equilibrium, was the base isolation of the whole structure linking all the 16 blocks in one rigid element except the car park block.

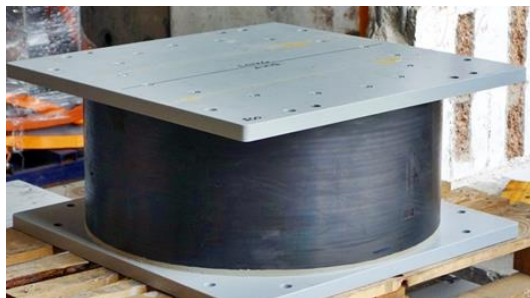

Figure 15. Marmara: LRB

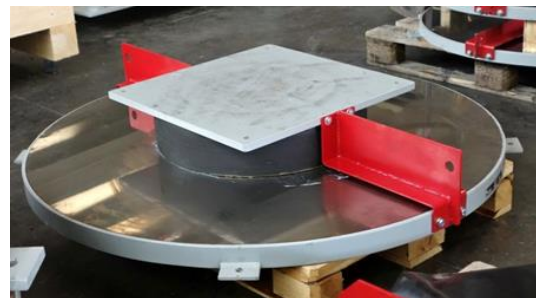

Figure 16. Marmara: NTM

Lead rubber bearings (LRB) have been used in parallel with sliding elastomeric bearings provided by sliding plate (NTM) for a total of 687 devices. The use of sliding bearings was necessary due to the very low global stiffness together required along with the high global damping.

### Test

All the LRB installed have been designed and tested according to European standard EN 15129 and they are provided of CE mark.

Initial type tests of the LRB devices have been performed at the laboratory of Eucentre (European centre for training and research in earthquake engineering) in Pavia (Italy) while the Quality control tests were performed at ISOLAB,

Also NTm, even provided by CE mark, were tested at Isolab both for checking the vertical load capacity and for checking the friction coefficient of the sliding surface through a dynamic test.

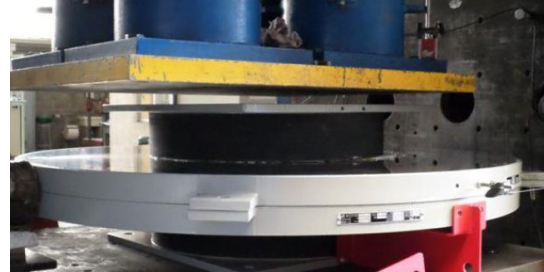

Figure 17. Marmara: Test on LRB at Eucentre    Figure 18. Marmara: Test on NTm at ISOLAB

#### *Installation procedure*

The installation of the devices required a preliminary structural strengthening for two main reasons: the first was geometric since a bearing surface was needed, while the second reason is linked to the design of an adequate reinforcement to resist to the horizontal loads acting during the seismic phase.



Figure 19. Marmara: Column before the installation

The installation of the isolators, performed by Freysaş, company of the Freyssinet Group based in Turkey, has followed a procedure which foresees the cut of the columns with temporary support of the vertical load through proper metallic structures.

This type of technology consists in the application to each column of two special steel clamps, which, after being positioned, they are clamped to the column through high strength steel prestressing bars. After that, hydraulic jacks are loaded and this allows for downloading the column from the building weight.

Finally, using a diamond wire, the part of the column is removed and the isolator can be installed just after having casted the corresponding masonry plates.



Figure 20. Marmara: Cut of the column with diamond wire

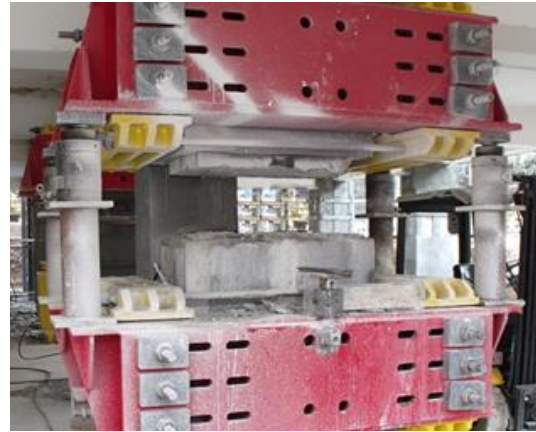

Figure 21. Marmara: Concrete block removal

The big advantage of an intervention of this type is the ease and speed of execution. Moreover, from the point of view of safety, this intervention does not present any criticality. The fact of operating in the same time on only a couple of columns and the possibility to minimize the deformation induced to the structure, guarantees the structural stability for all the time of intervention.



Figure 22. Marmara: Column after the installation

## Conclusions

The solutions presented in this paper show the great benefit of base isolation in strategic buildings worldwide. Base isolation with Lead Rubber Bearings is indeed a good solution that allowed to solve the seismic protection of these important structures under different reference standards for the assessment of the performance and of its constancy.

The success of the challenge is only possible thanks to the experience obtained with hundreds of tests which allows to have the necessary deep knowledge to respect the so different criteria given by norms and design specifications.

These projects highlight the know-how of the Freyssinet Group in the seismic protection sector and its capacity to offer a turnkey solution: from the seismic assessment of the building to the design of the optimum isolation system; from the design, production and testing of anti-seismic devices to their installation using innovative and efficient retrofitting techniques.

## References

Sartori M., Maraston S., Zivanovic I. (2017), Seismic Retrofitting of the Marmara Başibüyük University Hospital in Istanbul, *16WCEE Proceedings*